

## **DEVELOPMENT OF A COLD STORAGE FACILITY FOR AGRICULTURAL PRODUCE USING AIR CONDITIONER**

**Sanoj Kumar\*, Ashok Kumar and Satish Kumar**

Department of Agricultural Engineering, Bihar Agricultural College, Sabour,  
Bhagalpur, Bihar

E-mail: sanojk.cryo@gmail.com (\*Corresponding author)

BAU Communication No. 429/2018

**Abstract:** Although mechanical refrigeration is the best technology for cool rooms and transportation systems, conventional reefers are economically and practically infeasible for limited resource farmers. In present work a device “CoolBot” was tested along with selection of low cost insulation technology. CoolBot is a device, which turns a conventional room air conditioner into a produce cooler. The air conditioner thermostat is heated so that the unit keeps running until the room temperature reaches the CoolBot set point. To prevent icing of the fins, the CoolBot measures the fin temperature and stops the compressor (through the thermostat heater) when ice builds up. The ice on the fins continues to cool the room air until it melts and the compressor turns on again. The developed setup can go close to 0<sup>0</sup> C of room temperature within 2 hour of running.

**Keywords:** CoolBot, air-conditioner, cold storage, R value, thermostat.

### **INTRODUCTION**

For fruit and vegetable farmers selling directly to consumers, the ability to quickly chill produce after harvest and safely store it until delivery can make or break the value of a crop. For larger community of farmers, a walk-in cooler is one of their first large capital farm expenses. The level of investment varies as per, capacity of the system, area, country and level of expertise, it may go to crores starting from lakhs. For maximum of farmers it is beyond their financial limits. Keeping this in view a new technology CoolBot may be tested with window air conditioners in our conditions, to understand the technical, economic, and environmental potential of the CoolBot controller that enables farmers to build a low-cost walk-in cooler for storing produce and other food products [1].

The controller allows a conventional room air conditioner (Room AC) to be used to maintain a walk-in cooler at temperatures as cold as 32°F. The controller connects to the air conditioner without wiring modifications and includes built in defrost cycles to prevent the unit from freezing/frosting up [2]. The CoolBot concept of low-cost storage allows local farmers to retain locally-grown produce for a longer period of time, thereby effectively

servicing more local customers. The approach provides greater income for the local farmer and offsets the need to transport food long distances. The ability to produce, store and consume food locally is expected to reduce the greenhouse gas (GHG) emissions associated with food transport [3].

The CoolBot approach of using a room AC slightly decreases on-farm electricity use compared to a conventional refrigeration system, which decreases GHG emissions; however, the impact is modest compared to the transport impacts. Since the CoolBot approach has a much lower installed cost than conventional refrigeration, it is expected to significantly increase the use of on-farm refrigeration and storage. Wide-spread adoption of the CoolBot concept will result in a net reduction in GHG emissions by reducing the need for food transport [4].

The CoolBot controller essentially “fools” an air conditioner into operating at much lower indoor temperatures. The controller also tracks the amount of frost buildup on the coil and periodically stops AC operation allowing the coil to defrost [4]. The concept provides a low-cost way to provide on-farm refrigeration down to 0 °C. While Room AC units were not designed to operate at these conditions, the characteristics of these highly-engineered products allow them to successfully operate at these off-design conditions.

The CoolBot controller is installed inside the cooler near the Room AC. The microprocessor-based controller unit includes three remote probes/sensors:

1. a room temperature sensor,
2. a defrost sensor that is placed next to the evaporator coil fins (on the outlet side),
3. a small heater element that attaches to the sensor bulb from the air conditioner that normally senses space conditions. This small heater is activated to make the AC run, and deactivated to stop cooling operation.

The controller maintains the cooler set point and controls the defrost initiation and termination settings. The human interface includes three buttons and LCD display.

Mechanical refrigeration is the best technology for coolrooms and transportation systems, conventional cold storages are economically and practically infeasible for limited resource farmers. A device named ‘CoolBot’ conceptualized by Mr. Ron Khosla was tested and verified in a low cost insulated room at Amity University Uttar Pradesh. This facility helped in maintaining the product storage temperature and relative humidity. It also helped to save not only on installation and repair costs but also reduces electricity bill and lower carbon foot

print. This technology can easily serve in small scale cool rooms and small scale transportation facilities losses [5].

An insulated room with capacity 8-10 MT was constructed along with an ante room at Amity University Uttar Pradesh. The insulating material used was 3 ft thick clay mud and rice husk along with untreated bricks for stability and support. The door of the cool room was a standard cold store door with 60 mm thick PUF. Roof and floor were insulated with polythene enclosed thermocool sheets which also acted as vapour barrier. A good energy efficient window Air conditioner unit was installed in the wall depending on the size of the room and the gap was sealed with the foam sealant. The CoolBot was mounted in the wall besides the Air conditioner and connected to the air conditioner. The data was recorded with the help of the pico logger [6].

### **MATERIALS AND METHODS**

The Cold Storage facility has been developed in a vacant room in the department of Agricultural Engineering. Initially the room was having two nos. of doors, which was not suitable for the construction of Cold Storage facility, due to heat losses from two doors. Keeping above in view, one door was closed with various insulation materials. In mean-time salwood was used as columns of various sizes for the outer construction of the Cold Storage facility as well as front room, and clamped with each other to provide stability to the entire structure. The cross sectional view of the developed room is shown in Fig. 1. The various dimensional parameters of the structure are as below:

- Cold Storage facility Outer Dimension: 80''\*101''\*123''
- Cold Storage facility Inner Dimension: 69.25''\*92''\*115''
- Cold Storage facility door dimension: 1.25''\*36''\*78''
- Front room dimension : 56''\*101'' \* 80''
- Floor area: 55 sq-ft

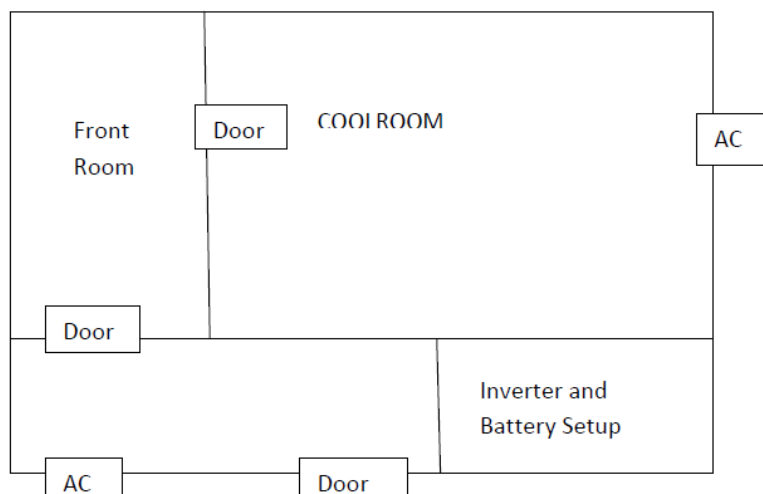

**Fig.1. Cross Sectional View of the developed cold storage facility**

During construction of Cold Storage facility, the structure was initially divided into Six parts, say:

- i. Floor Construction
- ii. Side wall construction without brick wall support
- iii. Side wall construction with brick wall support
- iv. Roof construction
- v. Door
- vi. Front room

For minimum heat losses, all the sides of the storage room had to be heat proof. For this, a minimum value of  $R=20$  has been utilized. Thereafter, four parts namely, Floor Construction, Side wall construction without brick wall support, Side wall construction with brick wall support and Roof construction were made using various types of insulation materials, and plywood. The details are shown in tabular form (Table 1-4) as below:

**Table 1. Floor Construction**

Item	Thickness	Total thickness	R value
EPS Thermocole	2"	2"	10
Poly Ethylene Roll	1"	1"	3
Fiber Glass wool – 16 kg/cu-m	1"	2"	8
Floor Guard	5 mm	1"	1
Flooring	2 mm	2 mm	0.05
Plywood	6 mm	6 mm	0.744
<b>Total R-Value</b>			<b>22.79</b>

**Table 2. Side wall construction without brick wall support**

Item	Thickness	Total thickness	R value
EPS Thermocole	2"	2"	10
Fiber Glass wool – 16 kg/cu-m	1"	1"	4
Poly Ethylene Roll	1"	2"	6
Poly Ethylene sheet	2"	2"	4
Plywood	6 mm	12 mm	1.488
<b>Total R-Value</b>			<b>21.49</b>

**Table 3. Side wall construction with brick wall support**

Item	Thickness	Total thickness	R value
EPS Thermocole	2"	2"	10
Fiber Glass wool – 16 kg/cu-m	10"	10"	1.1
Poly Ethylene Roll	1"	1"	4
Poly Ethylene sheet	1"	2"	6
Plywood	6 mm	6 mm	0.744
<b>Total R-Value</b>			<b>21.84</b>

**Table 4. Roof construction**

Item	Thickness	Total thickness	R value
EPS Thermocole	2"	3"	15
Poly Ethylene Roll	1"	2"	6
Plywood	6 mm	12 mm	1.488
<b>Total R-Value</b>			<b>22.49</b>

**Door:** A door of size 1.25"\*36"\*78" has been used for entering inside the Cold Storage facility. The door is outside open type. Due to heavy condensation problem, one another front room was needed, as without a front room heat losses occurs through this door, and condensation of water is a big problem in such case on the outer sides of the door, reducing the life of door.

**Front room:** A front room with the dimension: 56"\*101" \* 80" was created, with another door facility. The construction was made using plywood as covering material, and salwood as

columns for stability. One door was made for entering inside the front room, made up of salwood for frame, and plywood (6 mm, waterproof) for covering from outside and inside.

Thermocole (2''\*1m\*0.5m), Floor Guard (5 mm, 650 GSM, 6'\*4'), Fiber Glass wool (1'')-16 kg/cu-m, Poly Ethylene Roll (1'') and Poly Ethylene Sheet (2'') were used as insulation material in the entire construction work. While 20 Nos. of waterproof Plyboard, 20 cu-ft Sal wood and 2 pieces of wooden doors were also used for framing of entire section.

### **Installation of CoolBot**

CoolBot was installed following the below mentioned procedure [1].

[1] Install the A/C unit up high on the wall in a central location in the cooler.

[2] Remove the plastic cover and filters from the front of your a/c unit.

[3] Close the "fresh air vent" on your A/C unit

[4] Find and Free your a/c's Temperature Sensor. It's the *only thing* attached to the front fins/grill of your air conditioner. Remove the clip and sensor from the fins.

[5] Hang your CoolBot on the wall on the bottom or to the lower side of the a/c that has the control panel.

[6] Connect the CoolBot HEATER to Air Conditioner's Temperature Sensor.

[7] Insert CoolBot Frost Sensor.

[8] Pick your temperature. Plug in CoolBot. TWO NUMBERS will appear in the display. The ROOM temp displays above the word Room. The temp of the a/c fins appears above the word Frost.

-Press the ROOM Button once to see what temp CoolBot is set to take your room to

-Press the ROOM Button multiple times to change the set-temp to your desired room temperature

-Press the FROST button once to see your frost detection setting.

-Press the FROST button Multiple Times to change the setting. "Frost" setting must be LOWER than "room" setting, also above freezing.

-Don't Press DELAY (default is 10 sec). Only change if there's a freezing problem

[9] Turn your A/C unit on. Set the temp on your A/C unit as low as it can go. (60-65F) and make sure your a/c unit is set at the highest fan speed and in "COOL" mode.

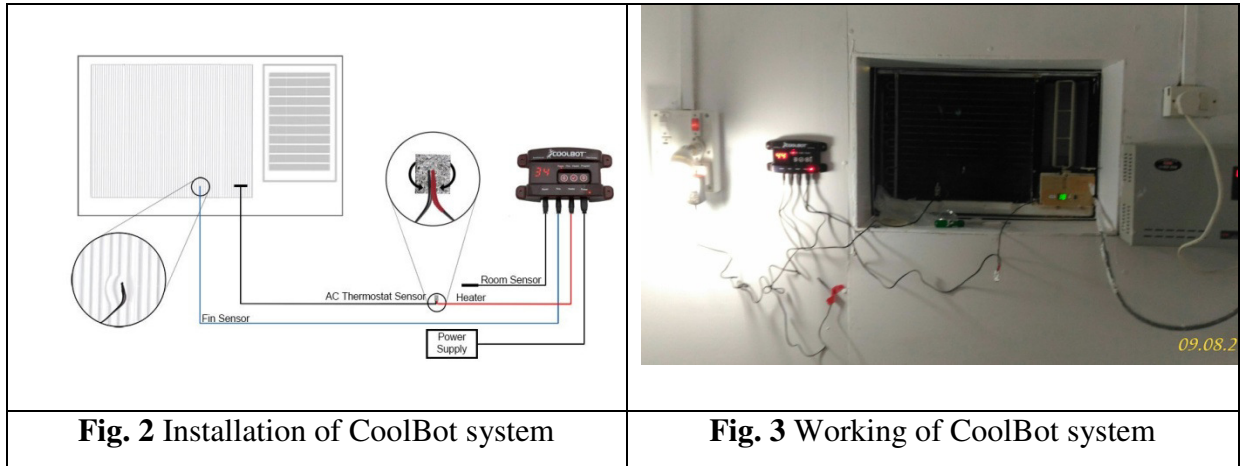

**RESULTS AND DISCUSSION**

Temperature and relative humidity were recorded inside the developed cold storage facility, and the results are shown in graphical form in Fig. 4. This experiment was conducted on 01.09.2017. The experiment shows that the setup took about 2 hours to reach and stabilize at about 0-1<sup>o</sup> C. The preliminary results indicated that a temperature level down to 1-10<sup>o</sup> C is easily achievable using this setup. The insulation material we used in the construction was found satisfactory in maintaining the desired temperature at the experimental level. The chart presented below clearly shows that the coolbot cool room maintains the lower temperature below 10 °C when the outside temperature ranges varying about 30 °C.

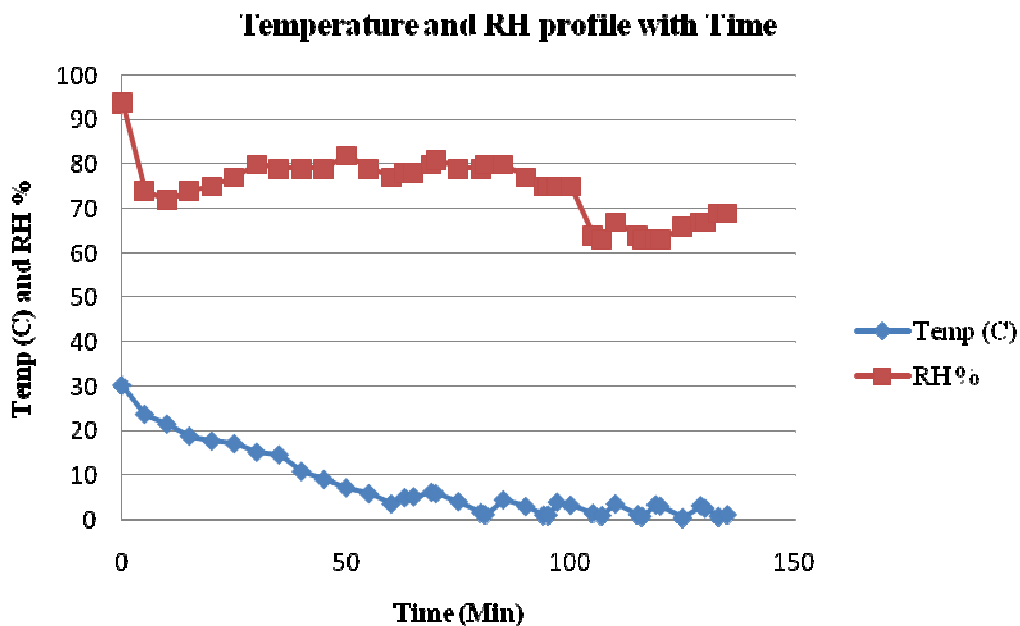

**Fig. 4.** Temperature and relative humidity variation with time in the developed setup

The CoolBot concept offers farmers a low cost means of providing on-farm refrigerated storage. The tables (Table 5 and 6) below estimate the costs for a conventional refrigeration system as well as costs for the CoolBot system. The cost of conventional system is about Rs. 4,00,000 compared to Rs. 1,25,000 for the CoolBot system. The cooler construction costs are assumed to be a separate construction item that is similar for both approaches. Therefore, the cost of the cooler is not included in the analysis.

**Table 5.** Installed Cost of Conventional Refrigeration System

Sr. No.	Item	Estimated price (Rs.)
1.	1.5 ton Air-Cooled Condensing Unit	150000
2.	15 MBtu/h Evaporator, Ceiling Mount, Air Defrost	250000
	Total	400000

**Table 6.** Installed Cost of CoolBot Room AC System

Sr. No.	Item	Estimated price (Rs.)
1.	2 Nos. of Air Conditioner, 2 Ton	90000
2.	CoolBot Controller	25000
3.	Installation (2 hrs)	10000
	Total	125000

The CoolBot concept of low-cost storage allows local farmers to retain locally-grown produce for a longer period of time, thereby effectively serving more local customers. The approach provides greater income for the local farmer and offsets the need to transport food long distances. The ability to produce, store and consume food locally is expected to reduce the greenhouse gas (GHG) emissions associated with food transport.

The CoolBot approach of using a room AC slightly decreases on-farm electricity use compared to a conventional refrigeration system, which decreases GHG emissions; however, the impact is modest compared to the transport impacts. Since the CoolBot approach has a much lower installed cost than conventional refrigeration, it is expected to significantly increase the use of on-farm refrigeration and storage. Wide-spread adoption of the CoolBot concept will result in a net reduction in GHG emissions by reducing the need for food transport.



## CONCLUSION

The developed system is a low cost chilling option. The electronics in the CoolBot apply heat to the AC temperature sensor. As the AC sensor is heated, the compressor turns on. A second CoolBot sensor monitors the evaporator, and turns the compressor off when the evaporator surface temperature nears the set point temperature. A window AC unit can thereby achieve temperatures far below the typical factory settings of 16-18°C. The result is a reduction in the efficiency for the AC unit. It is recommended that the window AC unit be installed such that no condensation reaches the wall which supports the unit. Water is an efficient conductor of heat, and will reduce the R-value of the wall – especially if fiberglass insulation is used. The walls and ceiling of a walk-in cooler must be designed and executed with care. The walls and ceiling must be air-tight, and should have a minimum R-value of 20. The CoolBot turns any brand of off-the-shelf, window-type air conditioning unit into a turbocharged cooling machine. With it a highly-insulated room can be transformed into a walk-in cooler, keeping the commodity fresh and thermostatically controlled cool down to near Zero to 10 °C. CoolBot saves not only on installation and repair costs but also helps to save electricity, reducing the operating costs when combined with new energy efficient air conditioning units.

## REFERENCES

- [1] <https://www.storeitcold.com/>
- [2] [http://extension.oregonstate.edu/fch/sites/default/files/documents/pnw\\_612\\_storingfoodforsafetyquality.pdf](http://extension.oregonstate.edu/fch/sites/default/files/documents/pnw_612_storingfoodforsafetyquality.pdf)
- [3] <https://www.storeitcold.com/wp-content/uploads/2016/02/coolbot-ReportMay09.pdf>
- [4] [https://cdn2.hubspot.net/hubfs/2434330/CoolBot%20DIY%20Construction%20ECO - Cooler.pdf](https://cdn2.hubspot.net/hubfs/2434330/CoolBot%20DIY%20Construction%20ECO%20Cooler.pdf)
- [5] Dubey, N. and Raman, N.L.M. (2016). Low cost insulation for coolrooms using 'CoolBot'. *Acta Hort.* 1120, 279-284.
- [6] Neeru Dubey et al., Effect of CoolBot cool room on shelf - life of Cabbage and Cauliflower, *American International Journal of Research in Formal, Applied & Natural Sciences*, 13 (1), December, 2015 - February, 2016, pp. 66- 69.