

## **EFFECT OF MOBILE PHONE FREQUENCY RADIATION ON EARLY DEVELOPMENT OF CHICK EMBRYO**

**Jyoti<sup>1</sup>, Ravinder Kumar Kohli<sup>2</sup> and Upma Bagai<sup>1</sup>**

<sup>1</sup>Department of Zoology, Panjab University, Chandigarh-160014, India

<sup>2</sup>Department of Botany, Panjab University, Chandigarh-160014, India

Email: upmabagai@yahoo.co.in

**Abstract:** The countless increase in towers and mobile phones has increased the amount of non-ionizing radio waves in surroundings during last two decades. Several reports have revealed non-desirable after effects of mobile phone frequency electromagnetic field radiations at cellular level. Thus, the present study was designed to evaluate the effect of cell-phone frequency electromagnetic field (EMF) radiations on early development of chick embryos. To carry out the studies, zero hour incubated fertilized eggs were divided into four groups including normal control and rest three EMF treated groups, exposed to 900 MHz EMF for different durations and at different power levels. During the study, higher mortality and somite development alteration in exposed groups has been observed as compared to normal control group. Hence, the study concludes that EMF exposure induces detrimental effects on development of chick embryo during early incubation period.

**Keywords:** EMF, chick embryo, mortality, somite.

### **Introduction**

Modern technology has provided comfort and ease to human society but various other non-avoidable factors are also associated with these technical and communication devices. Electromagnetic radiations are included in these factors which are used in cell-phones and wireless devices for signal transmission. Various research studies have illustrated that EMF radiations are found to be responsible for various harmful effects on health, development, reproduction, immune system, growth, sleep, skin and brain (Johansson, 2007; Hardell and Sage, 2008; Pourlis, 2009; Aziz et al., 2010; Konstantin and Korotkov, 2012; Bilgici et al., 2013). On the basis of various reports it has been found that EMF radiation adversely affect development which is supported by the results showing additional chick embryo mortality, significant delayed development and induced malformations in EMF exposed group as compared to normal control (Batellier, 2008; Zareen and Khan, 2008).

Various investigations have revealed the toxic effects of EMFs on brain cells of chick embryos which included increased number of apoptotic cells, degeneration of brain's tissues, severe hemorrhages and early death in embryonic stages. Similarly, other abnormal early

developmental observations found trunkal torsion, microphthalmia and neural tube malformations (Lahijani and Ghafoori, 2000; Lahijani et al., 2011).

A long EMF treatment study for 45 min per day up to 21 days of development, the hatched chick birds showed higher expression of neural marker NSE (neural specific enolase) and very low expression of glycosaminoglycans as determined by immuno-histochemistry suggested that pulsed magnetic fields may be able to alter normal embryonic development and normal neural functioning (Roda et al., 2011).

A recent study has shown the toxic effects of EMF on developing chick embryo brain cell organelles and membranes, affected blood brain barrier permeability, increased cellular apoptosis and torn blood vessels (Kalantari et al., 2014). Another biochemical study on blood plasma of newly hatched chick embryos has found adverse effects of EMF exposure on endocrine system, having increased corticosterone level and decreased T<sub>3</sub> and T<sub>4</sub> concentrations (Pawlak et al., 2014). On the other hand, a development study has opined that EMF emitted by a mobile phone may cause derangement of chicken embryo retinal differentiation (Zareen et al., 2009).

Although various researches and studies have noticed that EMF radiations are responsible for defects at tissue and differentiation level and also affect on growth rate. The present study is also an effort for determining the effect of duration and intensity of mobile phone radiation treatment on earlier stages of development.

### **Materials and Methods**

**Eggs-** Zero hour incubated, fertilized chick eggs (60-70 g weight) were procured after collection from Central Poultry Development Organization, Industrial Area, Chandigarh, India. All the procedures were followed according to Ethical Guidelines for care and use of experimental animals approved by Institutional Animal Ethics Committee (IAEC), Panjab University, Chandigarh, India.

#### ***Exposure arrangement and dosimetry:***

The source of EMF was Agilent 9310A RF Signal Generator (range 9KHz-3GHz) connected to power amplifier supplied with direct current (DC) (fig.1). EMF exposure was given with the help of antenna attached to amplifier and headed inside the incubator (Narang Scientific Works, Delhi, India).

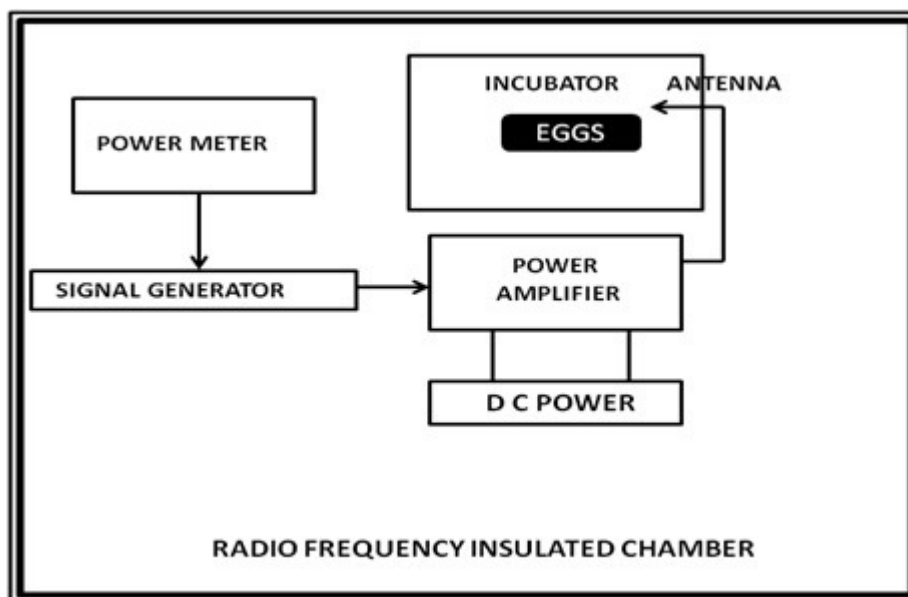

**Fig: 1.** Diagrammatic presentation of EMF exposure system arrangement in a chamber

**EMF exposure procedure:** Two different studies were performed, where fertilized chick eggs were exposed with transverse EMF 900 MHz for different durations and power levels at incubation temperature of  $38\pm 0.5^{\circ}\text{C}$  placed in egg tray in the horizontal array of  $3\times 2$ . Electromagnetic field parameters were measured continuously during experimental period with the help of RF field strength meter (Spectran HF-4060).

After the completion of exposure period, the eggs were removed from incubator and window were prepared in the egg shell, embryos were fixed in Bouin's fluid and removed after 30 min followed by hot saline wash and were left in fixative for 2 h. The developed embryos were observed through a Radical Zoom Stereo Trinocular Microscope attached with digital camera. Later on, scoring was done for various gross features which included number of somite pairs, eyes, heart, flexure, development, vascular system in all groups and compared with Hamburger and Hamilton illustrations, 1951.

**Experimental Groups:** There were four groups (G-1 to G-4) each consisting of six eggs, for both experiments. G-1 was considered as normal control and not exposed to cell-phone radiation. G-2, G-3 and G-4 groups were exposed to cell-phone EMF-r (900 MHz) with the help of an antenna connected to Signal Generator (Agilent 9310A) for zero,  $\frac{1}{2}$ , 1 and 1h, at different power level of zero, 20, 20 and 10 (dBm) respectively for two different experiments.

| Groups | No. of eggs (n) | EMF exposure (h/day) | Power level (dBm) |
|--------|-----------------|----------------------|-------------------|
| G-1    | 6               | -                    | -                 |
| G-2    | 6               | ½                    | 20                |
| G-3    | 6               | 1                    | 20                |
| G-4    | 6               | 1                    | 10                |

**Table 1:** Various experimental groups and exposure conditions

**Experiment 1:** Effect of EMF exposure on embryonic mortality of 3 days incubated eggs.

**Experiment 2:** Effect of EMF exposure on embryonic somite development of 1 day incubated eggs.

### Results and Discussion

The present study was an effort towards the estimation of influencing effects of mobile phone radiations on early development of vertebrates. The most observable and frequent observations were mortality rate and rapid somite development in developing chick embryos. The study provided important findings related to different developmental stages under same radio frequency exposure (900 MHz).

Firstly, it has been found that RF-EMF exposure at 900 MHz showed higher mortality ratio in G-3 at exposure duration of 1h and higher power level (20 dBm). Exposure duration was more in G-3 but the power level was similar in both G-3 and G-2 groups (1/2 h, 20 dBm). The increased exposure duration and higher power level (1h; 20 dBm) both had influenced the mortality ratio in EMF exposed groups (1/2 h; 10dBm) in comparison to normal control. However, under shorter exposure period and low power level conditions in G-4 (1/2 h, 10 dBm), the mortality ratio was lesser than other exposed groups, but greater than normal control. The present study showed reduced hatchability and increased death ratio under the influence of long exposure duration and high power level of EMF radiation. Regarding mortality, the percentage ratios are shown in fig2.

Secondly, at earlier developmental stages exposure, the results revealed (fig 3) that after an incubation of 24-28 h, the control group (G-1) showed normal well developed somite pairs in light microscopy. On the other hand, in other exposed groups under the influence of increased power level and duration of the exposure, the somite number was more than normal control.

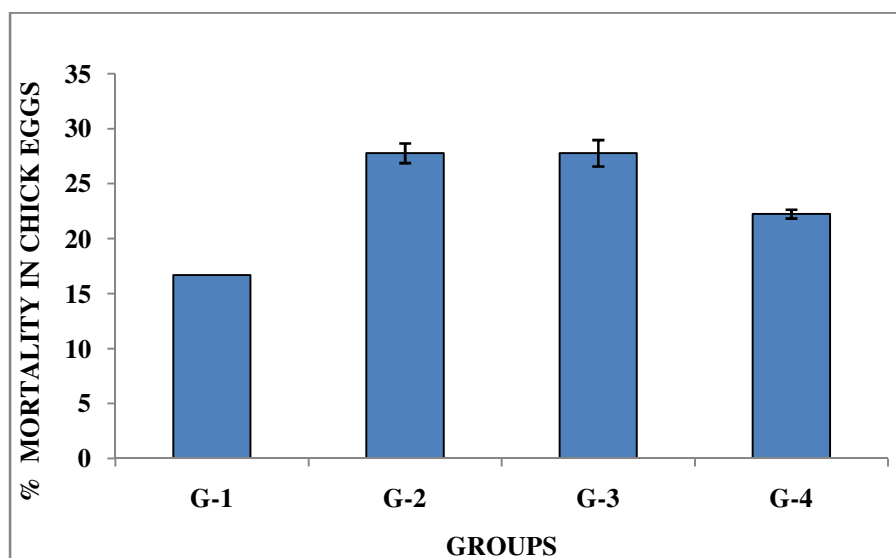

**Fig. 2.** Percent mortality of various group (G-1 to G-4) of chick egg embryo 72-74 h after incubation (n=6),

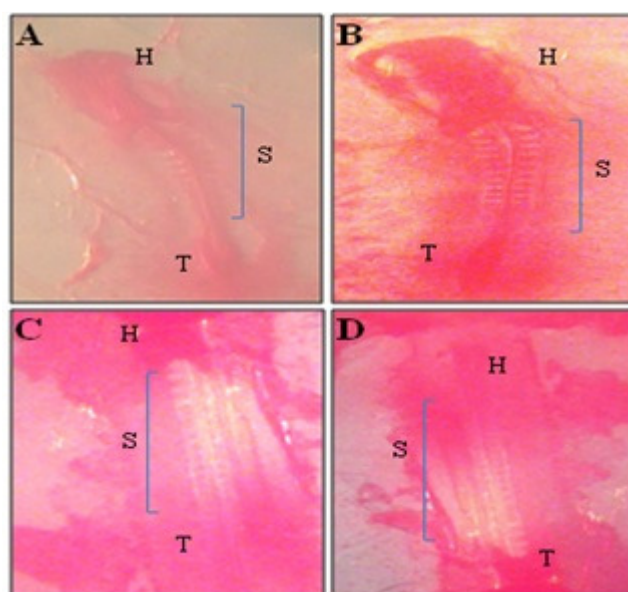

**Fig. 3.** 24-28 h; (A-G1); (B-G2); (C-G3) and (D-G4); [H-Head, S-Somites, T-Tail x40]

These results have revealed the adverse effects of non-ionizing EMF radiation during earlier prenatal stages. Some previous studies are in support of these results, performed at extremely low frequency electromagnetic field (ELF-EMF) at 50 Hz and 900 MHz respectively and reported high mortality ratio in chick embryos (Batellier et al., 2008; Lotfi and Narimani, 2012).

The results of exposure study at 900 MHz revealed that under these conditions, developmental changes in 24 h chick embryos and confirm that EMF strength and duration

could be the causal factor for the embryonic response towards EMF radiation (Lahijani and Ghafoori, 2000). Previously, various other studies have found the altering effects of EMF radiation on 24 h developing chick embryos (Farrell et al., 1997; Costa et al., 2013).

The cause of these earlier developmental abnormalities might be due to exposure at earlier stages of incubated eggs. The electromagnetic field might be affecting intracellular proteins, RNAs and DNAs, cellular metabolism, division and growth with respect to morphogenetic growth which influence the organ development on later stages of development (Adey, 1990; Chernoff et al., 1992; Nordenson et al., 1994).

### **Conclusion**

On the basis of present findings it can be concluded that earlier stages of development are very sensitive towards any external change in normal surrounding and high frequency electromagnetic field can be responsible for bringing alterations in growth and development *in ovo* amniotic vertebrates.

### **Acknowledgement**

The authors acknowledge the support provided by Ministry of Environment and Forests (MoEF), New Delhi, India for providing financial assistance to carry out this work under the project ref. 14/28/2008-ERS/RE.

### **References**

- [1] Adey W (1990). Cell membrane: The electromagnetic environment and cancer promotion. *Neurochem. Res.*, 13 (7): 671-677.
- [2] Aziz Abdel, El-Khozondar HJ, Shabat M and Elwasife K (2010). Effect of electromagnetic field on body weight and blood indices in albino rats and the therapeutic action of Vitamin C or E. *Romanian J. Biophys.*, 20 (3): 235-244.
- [3] Batellier F, Couty I, Picard D and Brillard JP (2008). Effects of exposing chicken eggs to a cell phone in “call” position over the entire incubation period. *Theriogenology*, 69 (6): 737-745.
- [4] Bilgici B, Akar A, Avci B and Tuncel OK (2013). Effect of 900 MHz radiofrequency radiation on oxidative stress in rat brain and serum. *Electromagn. Biol. Med.*, 32 (1): 20-29.
- [5] Chernoff N, Rogers JM and Kavet R (1992). A review of the literature on potential reproductive and developmental toxicity of electric and magnetic fields. *Toxicology*, 74: 91-126.

- [6] Costa EV, Jimenez GC, Barbosa CT and Nogueira RA (2013). Fractal analysis of extra-embryonic vascularization in Japanese quail embryos exposed to extremely low frequency magnetic fields. *Bioelectromagnetics*, 34 (2): 114-121.
- [7] Farrell JM, Litovitz TL, Penafiel M, Montrose CJ, Doinov P, Barber M, Brown KM and Litovitz TA (1997). The effect of pulsed and sinusoidal magnetic fields on the morphology of developing chick embryos. *Bioelectromagnetics*, 18 (6): 431-438.
- [8] Hardell L and Sage C (2008). Biological effects from electromagnetic field exposure and public exposure standards. *Biomed. Pharmacother.*, 62: 104–109.
- [9] Hamburger V and Hamilton HL (1951). A series of normal stages in the development of chick embryo. *J. Morph.*, 88 (1): 49-92.
- [10] Johansson O (2009). Disturbance of the immune system by electromagnetic fields- A potentially underlying cause for cellular damage and tissue repair reduction which could lead to disease and impairment. *Pathophysiology*, 16 (2-3): 157-177.
- [11] Kalantari S, Bigdeli MR and Lahijani MS (2014). Cellular apoptosis and blood brain barrier permeability changes in the pre-incubated chicken embryo's brain by effect of electromagnetic fields. *Zahedan J. Res. Med. Sci.*, 16: 29-34.
- [12] Konstantin GK and Korotkov (2012). Effects of exposure to electromagnetic fields. *Measuring Energy Fields: Current Research. Environment*, 183-193.
- [13] Lahijani MS, Bigdeli MR and Kalantary S (2011). Effects of sinusoidal electro-magnetic fields on histopathology and structures of brains of pre-incubated white leghorn chicken embryos. *Electromagn. Biol. Med.*, 30 (3): 146-157.
- [14] Lahijani MS, Farivar S and Khodaeian M (2011). Effect of 50 Hz electromagnetic field. *Electromagn. Biol. Med.*, 30 (3): 158-169.
- [15] Lahijani MS and Ghafoori M (2000). Teratogenic effects of sinusoidal extremely low frequency electromagnetic fields on morphology of 24 hr chick embryos. *Indian J. Exp. Biol.*, 38 (7): 692-699.
- [16] Lotfi A and Narimani RM (2012). Effect of exposure to extremely low frequency electromagnetic fields (50 Hz, 0.5 mT) during incubation on hatchability, T<sub>3</sub> and T<sub>4</sub> levels in newly-hatched chicks. *Asian J. Anim. Vet. Adv.*, 7: 733-738.
- [17] Pawlak K, Sechman A and Nieckarz Z (2014). Plasma thyroid hormones and corticosterone levels in blood of chicken embryos and post hatch chickens exposed during incubation to 1800 MHz electromagnetic field. *Int. J. Occup. Med. Env. Heal.*, DOI 10.2478/s13382-014-0222-7.

- [18] Pourlis AF (2009). Reproductive and developmental effects of EMF in vertebrate animal models. *Pathophysiology*, 16 (2-3): 179-189.
- [19] Roda O, Garzon I, Carriel V, Alaminos M and Sanchez-Montesinos I (2011). Biological effects of low-frequency pulsed magnetic fields on the embryonic central nervous system development: A histological and histochemical study. *Histol. Histopathol.*, 26 (7): 873-881.
- [20] Tsybulin O, Sidorik E, Kyrylenko S, Henshel D and Yakymenko I (2012). GSM 900 MHz microwave radiation affects embryo development of Japanese quails. *Electromagn. Biol. Med.*, 31 (1): 75-86.
- [21] Zareen N and Khan MY (2008). Effect of mobile phone induced electromagnetic fields on the development of chick embryo. *J. Coll. Physicians Surg. Pak.*, 18 (8): 528-530.
- [22] Zareen N, Khan MY and Ali Minhas L (2009). Derangement of chick embryo retinal differentiation caused by radio frequency electromagnetic fields. *Congenit. Anom.*, 49 (1): 15-19.